

Development of an Instrumentation for Study the Effect of Relative Humidity on Strain Anisotropy of Wood

Kunjolata Kalita^{1*}, Nipan Das², Utpal Sarma³ and Pradip K. Boruah⁴

^{1,2,3,4}Dept. of Instrumentation & USIC Gauhati University
E-mail: *kunjolatakalita@yahoo.co.in

Abstract—Wood is an anisotropic engineering material with a variety of applications. The paper describes a measurement system of strain anisotropy of wood samples in response to the change in relative humidity (RH). The developed system measures ambient RH and corresponding strain of wood samples simultaneously. For the strain measurement of wood, strain gauges are attached on the surface of the wood samples in longitudinal and tangential direction. The necessary signal conditioning circuit for strain gauge is based on quarter bridge method with high precision resistors which is excited by an AC source. A 10-bit resolution data acquisition system has been developed for online measurement of RH and strain data. Strain anisotropies of two wood samples are tested at different relative humidity conditions and the results are reported in the paper. Experimental results show that the strain in tangential direction with RH is greater than in longitudinal direction.

1. INTRODUCTION

Wood is a hygroscopic material. Wood exchanges moisture with air, the amount and direction of the exchange (gain or loss) depends on the relative humidity and temperature of the air and the current amount of water in the wood. The exchange of moisture due to changes in ambient relative humidity and temperature affects the dimension of wood. To use wood to its best advantage and most effectively in engineering applications its specific characteristics or physical properties must be considered. The versatility of wood is demonstrated by a wide variety of products. This variety is a result of a spectrum of desirable physical characteristics among many species of wood [1].

Shrinkage and swelling of wood is not the same in the different grain directions. The greatest dimensional change occurs in a direction tangential to the annual rings. Shrinkage from the pith outwards, or radially, is considerably less than the tangential shrinkage, while shrinkage along the grain is so slight that it can be neglected [2].

Several research works have been done and are still going on to study wood response with the changes of environmental humidity. Ahmad et al. studied the hysteretic swelling and

shrinkage for latewood and earlywood by phase contrast X-ray tomography [3].

K.B. Dahl et al. developed video extensometer technique for the measurement of planer strain of wood [4].

Ahmad et al. documented the hygroscopic swelling and shrinkage of the central and the thickest secondary cell wall layer of wood in response to changes in environmental humidity using synchrotron radiation-based phase contrast X-ray tomographic nanoscopy. They found that the volumetric strains at the cell wall level are significantly larger than those observed at cellular tissue [5].

For measurement of change in strain of wood with RH it is essential to have an instrumentation for measuring both change in RH and corresponding changes in strain of the sample. Proper signal conditioning circuits are used to increase the reliability of the developed system.

The measurement system includes strain gauge, temperature sensor and humidity sensor to measure strain change of wood, ambient temperature and RH. The outputs of the sensors are sequentially read by 10-bit PIC18F43K22 microcontroller. The system firmware for microcontroller is developed on MPLAB-IDE and suitable codes are written on C-language for handling data in the PC side.

To test the variation of strain of different wood samples with RH, five different binary saturated salt solutions are used to generate different level of humidity within desiccators. The RH and temperature inside the desiccators are continuously monitored until they reach stable level of humidity. Strain developed in the wood samples is measured when RH attains stable level.

2. SYSTEM ARCHITECTURE

The block diagram of the instrumentation is shown in Fig. 1.

It includes the sensors along with their signal conditioning circuit for the measurement of temperature, relative humidity

and strain change of wood sample with relative humidity. TSIC 506F temperature sensor, HIH5030 humidity sensor and CF350-2AA (11) C20 strain gauge are interfaced to PIC18F43K22 microcontroller and connected to PC by RS232 communication. The output of the temperature sensors and strain gauges are fed to the six channels of the 10-bit on chip ADC of the microcontroller through proper signal conditioning circuit. The system features data display on LCD and online data collection on PC using RS-232 communication.

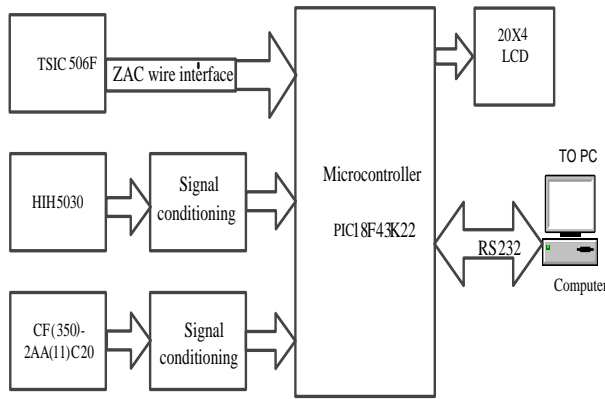

Fig. 1: Block diagram of the measurement system

3. IMPLEMENTATION

Different modules are designed and developed separately and finally integrated together for implementing of the system. The necessary signal conditioning circuits are designed to get voltage output in the input range of the integrated ADC of the microcontroller for the entire dynamic range of the sensors. Proper algorithm is developed to read the sensors and to get desired measurements of strain developed in wood samples along with temperature compensation for RH measurement. The developed code is implemented on the microcontroller. The measured values are displayed locally on 20X4 LCD and transmitted via RS232 communication to PC.

3.1 Sensors

For the measurement of temperature, TSIC 506F is used which gives digital output with an accuracy of ±0.1K. The ZACwire™ interface compatible sensor TSIC which is a factory calibrated temperature sensor and the digital output (T) of the sensor is given by [6]

$$T = \left[\frac{D}{2047} \times (T_H - T_L) + T_L \right] \tag{1}$$

Where, D is the 8 bit data from the temperature sensor and (T_H - T_L) being the temperature range of the sensor with T_L = -10 °C and T_H = 60 °C.

For measurement of humidity, HIH 5030 is used. It is a low voltage humidity sensors operate down to 2.7 V_{dc}. The

accuracy of the humidity sensor is ±3%. The output voltage V_{out} and RH is related by the following equation at 25°C [7]

$$RH = \left[\frac{V_{out}}{0.00636 \times V_{supply}} - 23.82 \right] \% \tag{2}$$

For measurement of strain of wood sample CF350-2AA (11) C20 strain gauge sensor is used which has the nominal resistance 350Ω with gauge factor 2.13 ± 1% [8].

3.2 Signal conditioning of strain gauge

The signal conditioning of strain gauge includes bridge, instrumentation amplifier and peak detector circuit.

A quarter bridges with three fixed resistors and one strain gauge (which is attached to the wood sample) is used for strain measurement. Each of the 350Ω fixed value resistors has tolerance of ±0.1% and temperature co-efficient ± 5ppm/°C which ensure very low temperature drift. The bridge is excited by 1 KHz, 5V (peak-peak) sinusoidal signal (amplitude accuracy, ±1mVpeak to peak) from the Agilent Function generator (Model no. 33220A). The differential output of the bridge is amplified by an instrumentation amplifier (AD620) and the amplified AC output is converted to DC by using peak detector (Fig. 2).

The DC output of the signal conditioning circuit is given by

$$\frac{V_{out}}{strain} = \left(\frac{49.4 \text{ K } \Omega}{R_g} + 1 \right) \times \frac{V_{in}}{8} \times \frac{\Delta R}{R} \tag{3}$$

Where, V_{in} the excitation voltage, ΔR the change in resistance of the sensor and R is the resistance of the sensor in the unstrained condition, R_g is the gain setting resistor.

4. SAMPLE PREPARATION

Two wood samples of pine (*Pinus spp.*) in different sizes are chosen and prepared for experiment. The sample 1 (S1) has the dimensions of 5cm X 1.7cm X 2.8 cm and sample 2 (S2) has 5cm X 1.7cm X 1.3 cm. The wood samples are cleaned well and sanded with grit size 1500 for smoothing the surface. Prior to the experiments, the samples are oven dried at 90°C and stored in a desiccator.

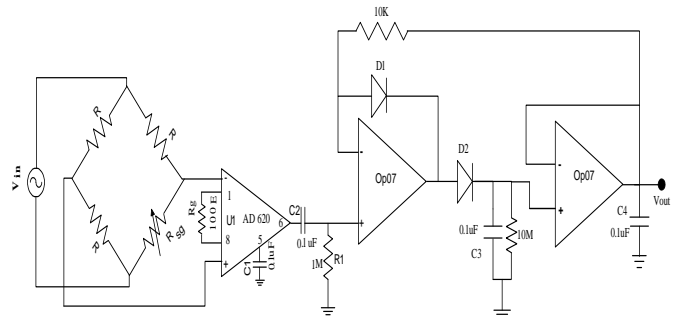

Fig. 2: Signal Conditioning Circuit of the strain gauge

Two strain gauges are attached by cyanoacrylate adhesive on each of the sample, one in longitudinal (L) and other in tangential (T) direction. Finally the connecting leads are soldered and connected to the bridge circuits.

Binary saturated salt solutions, prepared as per OIML R121 [9] in a desiccator at constant temperature generate fixed level of humidities with uncertainties [9] as shown in Table 1. A desiccator sealed with silicon high vacuum grease is used in the experiment to generate different fixed levels of humidity using the salts shown in Table 1. The samples under test and sensors are placed inside the desiccator as shown in the Fig. 3.

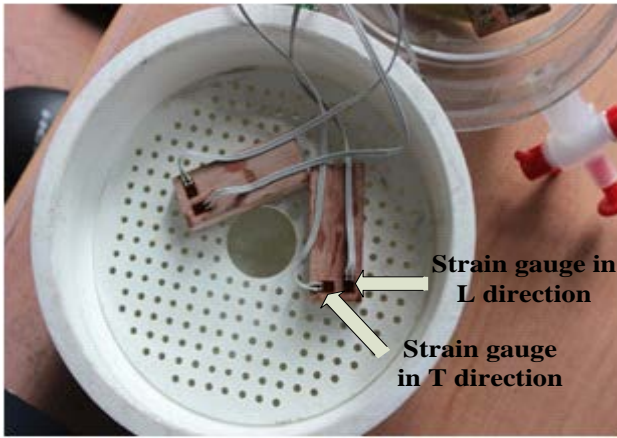
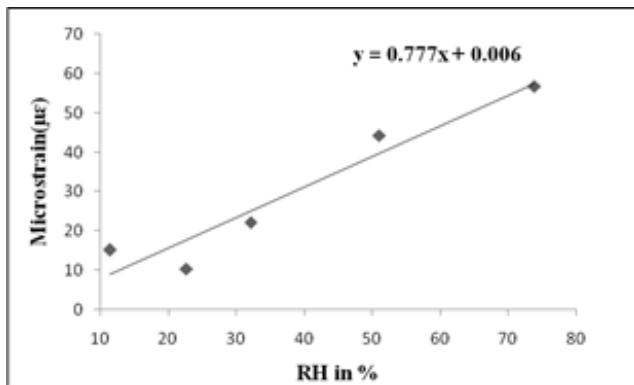

Fig. 3: Experimental set up during sample test at different RH level

Table 1 Levels of humidity generated by binary salt solutions at 25°C

5. EXPERIMENTAL RESULTS

During the experiment the samples under test are placed inside the desiccator for different levels of humidity generated by various salt solutions at 25°C (±1°C). At the stable level of humidity, data are recorded at an interval of one minute. Variations of strain changes of the samples are observed for different levels of humidity and plotted in Fig. 4 and Fig. 5.



(a)

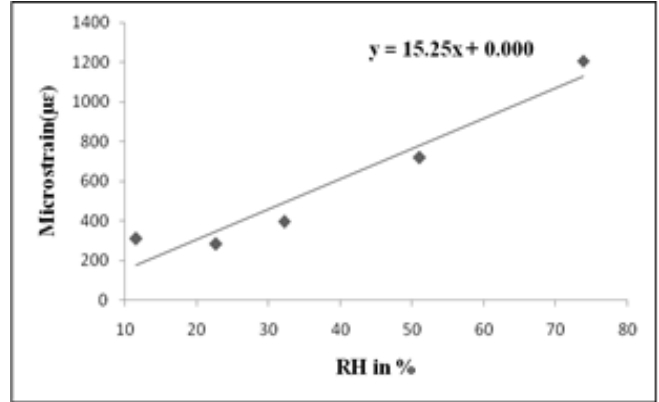

(b)

Fig. 4: Strain variation of S1 vs RH (a) in longitudinal and (b) tangential direction

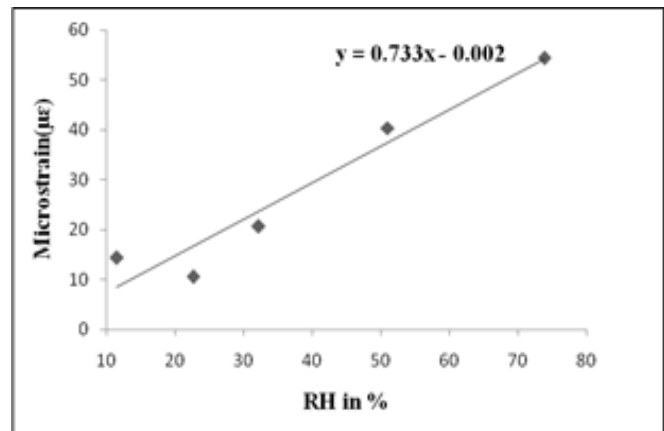

(a)

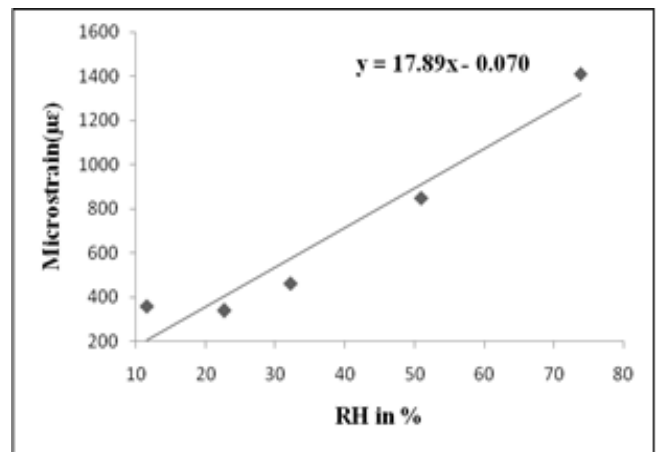

(b)

Fig. 5: Strain variation of S1 vs RH (a) in longitudinal and (b) tangential direction

The developed instrumentation system is capable of measuring the strain over the surface due to change in ambient relative humidity. The strain change of wood samples is found to be linear with the change in RH. Based on linear regression fitting, it is observed that the strain sensitivities of different wood samples in different orientation vary with change in relative humidity.

6. CONCLUSION

A strain measurement system is successfully developed which can be used to study the effect of RH on wood.

The strain sensitivities of S1 sample in tangential and longitudinal direction are $15.25\mu\epsilon/RH$, $0.777\mu\epsilon/RH$. For S2 sample the sensitivities in strain in tangential and longitudinal direction are $17.89\mu\epsilon/RH$, $0.733\mu\epsilon/RH$.

The observations agree with the related literature i.e. the difference in sensitivities reveals that the strains are anisotropic within the same sample [2].

7. ACKNOWLEDGEMENT

We acknowledge Assam Science Technology and Environment Council for financial support of this work. Dr. Kalyanee Boruah is also acknowledged for her helping in statistical analysis.

REFERENCES

- [1] GTR-FPL-I13.USDA Forest Service Wood Handbook:Wood as an Engineering Material., Forest Product Laboratory, (1999) Madison
- [2] Kollmann F.F.P, Cote W.A(1968),Principles of wood science and technology I solid wood, Springer-Verlag, New York Inc.
- [3] Rafsanjani A, Stiefel M, Jefimovs K, Mokso R, Derome D, Carmeliet J, Hygroscopic swelling and shrinkage of latewood cell wall micropillars reveal ultrastructural anisotropy. Journal of the Royal society interface, (2014) ,11:95
- [4] Dahl KB, Malo KA, Planar strain measurements on wood specimens, Experimental Mechanics (2009), 49:575–586
- [5] Derome D, Rafsanjani A, Patera A, Guyer R, Carmeliet J,Hygromorphic behavior of cellular material: hysteretic swelling and shrinkage of wood probed by phase contrast X- ray Tomography. Philosophical Magazine, (2012) 92:28-30
- [6] IST innovative sensor technology, Tsic 506F TO 92, accessed on 2nd August, 2015
- [7] Honeywell, HIH-5030, accessed on 1st August, 2015
- [8] Datasheet of strain gauge, accessed on 12th June, 2015
- [9] Wiederhold PR Water vapor measurement: Methods and Instrumentation, CRC Press, (1997),